



PRODUCT SPECIFICATIONS

PermaCap[®] 5 Coarse Bubble Diffuser

- Low capital and maintenance cost
- 5 inch diameter for greater air distribution
- Engineered air outlet orifices
- Non-clog design
- Durable ABS body & membrane retainer ring
- UV Protection
- Units in stock for immediate shipment



3/8 or 3/4 inch MPT (male) connection



Advanced Technology EPDM Membrane



Optional UDM for non-threaded connections

PermaCap has greater unit capacity over other small diameter diaphragm coarse bubble diffusers at less cost

EDI PermaCap diffusers are ideal for aeration applications where intermittent coarse bubble operation is desired. PermaCap units are available with either 3/8 inch or 3/4 inch NPT threaded (male) inlet to allow quick and simple installation into threaded pipe applications. Optional UDM (Universal Diffuser Mount) is available for non-threaded applications. Units are particularly well suited for single drop pipe installations in package treatment plants and channel aeration.

The diffuser assembly features a flexible membrane element that is configured to exclude solids during idle operations providing long-term trouble free operation. The flexible membrane features a non-perforated area that is directly aligned with the air outlet port. During idle operation the membrane retracts and seals the air exit port reducing back flow into the unit. The membrane element is mechanically engaged with the diffuser assembly preventing the membrane from disengaging from the diffuser assembly.

The PermaCap is suitable for installation on bottom (preferred) or top of diffuser piping. PermaCap coarse bubble units offer great value as a low cost aeration/mixing solution.

**MADE IN
USA**

EDI - Worldwide Headquarters
5601 Paris Road • Columbia, MO 65202 USA
+1 (573)-474-9456 • www.environmentaldynamics.com



PRODUCT SPECIFICATIONS

- Internal check valve to prevent entry of solids into piping
- Promotes fluid interaction with maximum bubble formation and dispersion
- Preferred mounting on bottom of air piping
- High airflow capacity
- Membrane interlock feature prevents blow out

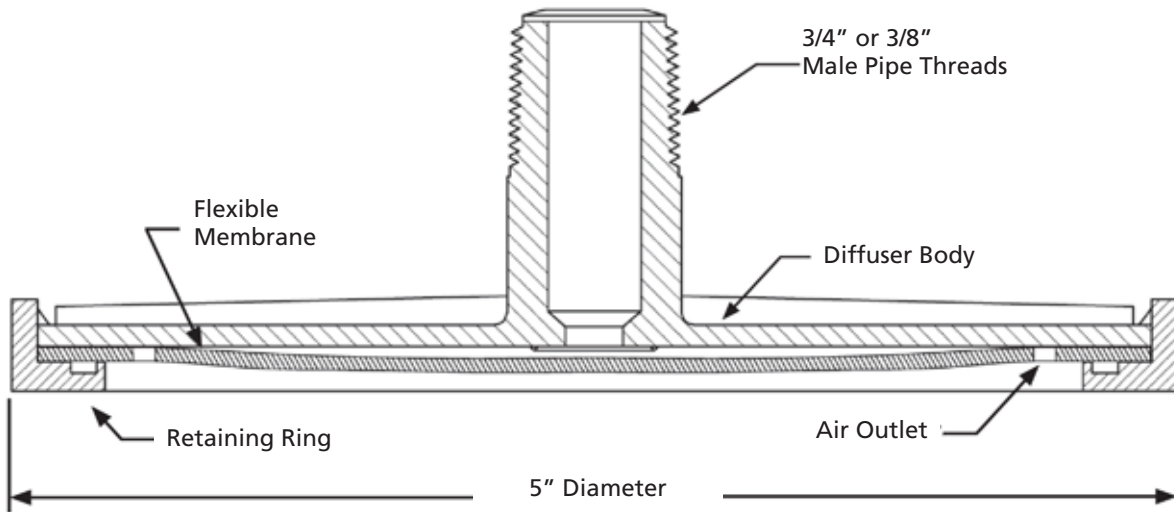
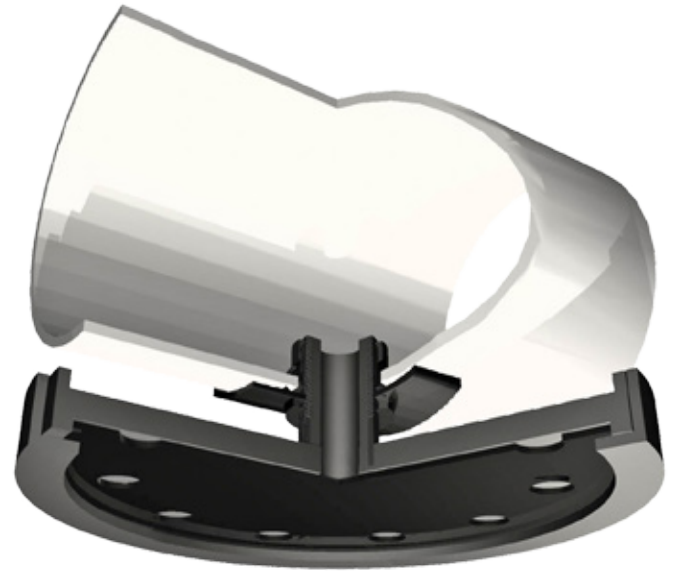

Diffuser Type	Orifice	Design Airflow		Overall Diameter		Active Surface Area		Dry Weight		Net Operating Buoyancy	
		scfm	Nm ³ /h	in	mm	ft ²	m ²	lb	kg	lb	kg
PermaCap (Coarse)	3/8" Orifice	2-20	3-32	5.00	127	0.13	0.012	0.19	0.087	0.040	0.018
	3/4" Orifice	2-20	3-32	5.00	127	0.13	0.012	0.20	0.091	0.049	0.022
PermaCap (Medium)	3/8" Orifice	1-8.0	1.6-13	5.00	127	0.13	0.012	0.19	0.087	0.040	0.018
	3/4" Orifice	1-8.0	1.6-13	5.00	127	0.13	0.012	0.20	0.091	0.049	0.022
PermaCap (Fine)	3/8" Orifice	0.5-2.0	0.8-3.2	5.00	127	0.13	0.012	0.19	0.087	0.040	0.018
	3/4" Orifice	0.5-2.0	0.8-3.2	5.00	127	0.13	0.012	0.20	0.091	0.049	0.022

- The approximate operating pressure of the diffuser at the mid-range is 5 to 10 inches (1.2 - 2.5 kPa).