

**DUMPSTER-VEYOR 2<sup>TM</sup>**  
**Patented Container Handling System**  
*Equipment Specifications*

1.0 GENERAL DESCRIPTION

A. DESIGN / MANUFACTURER

- 1.1 The Dumpster-Veyor is designed to provide the operator a means to evenly distribute material into a roll-off container being deposited from a conveyor or chute. The system has a rated capacity of **20 tons, with an optional capacity of 30 tons.**
- 1.2 The components of the Dumpster-Veyor include two (2) runs of runway track with anchors, two (2) drive tracks, one (1) idler articulating carriers, one (1) drive articulating carrier, one (1) positive control dual directional closed loop drive system with controls and one (1) return sheave.
- 1.3 The Dumpster-Veyor shall be manufactured by D. R. Cordell & Associates, Inc., Chalfont, PA 18914.(215)822-9345.

2.0 COMPONENTS

A. RUNWAY AND DRIVE TRACKS

- 2.1 The runway track shall be manufactured using **304 stainless steel** and be a built up fabricated section, providing a track system on which the drive and idler carts operate. Tracks shall be positioned under a discharge point so that the track extends in either direction from the discharge point as shown on the drawings. Track length shall be as indicated on the drawings spaced at approximately 7'-6"
- 2.2 Track joints are spliced using a lap joint. Ends of adjoining tracks manufactured to allow the square bar to overlap the base plate. Track ends are shop fabricated to permit smooth transition from track section to track section during carrier travel. No field welding at track joints is required. The base plate is drilled at regular intervals for mounting to a flat concrete surface using expandable anchors or an epoxy anchor system.
- 2.3 The drive track shall be manufactured using a UHMW guide channel bolted directly to the concrete floor. The guide channel is drilled at regular intervals for mounting to a flat concrete surface using an expandable anchoring system or the epoxy system. Two tracks running from the drive winch to the idler sheave are required spaced at approximately 9" apart. The drive chain rides in the guide channel.

B. IDLER CARRIERS

- 2.4 One (1) low profile, heavy duty **304 stainless steel** idler carrier having a capacity of 10 tons, and a nominal plan size of 8'-3" by 2'-8" shall be provided for the container handling system. The idler carrier shall be assembled to prevent skewing and racking and to accurately accept the articulating wheel assemblies.
- 2.5 The carriers shall be drilled to ensure articulating axle alignment. The axles shall be held in place by retainer plates which are easily removable to allow component inspection. Dual wheel stops shall be provided to prevent wheel overload and container roll off when traveling. Stops shall be factory welded and located to clear any obstruction on the underside of the container.
- 2.6 The idler carrier shall be equipped with eight (8) double flanged, **304 stainless steel wheels** assembled into articulating trolley assemblies. Articulating trolley assemblies are designed to maintain equal wheel loading at all times during carrier travel. Wheels shall interface with the runway track to allow easy tracking and eliminate binding during travel.

C. DRIVE CARRIER

- 2.7 One (1) low profile, heavy duty **304 stainless steel** drive carrier having a capacity of 10 tons and a nominal plan size of 8'-3" by 2'-8" shall be provided for the container handling system. The unit shall be assembled to prevent skewing and racking and to accurately accept the articulating wheel assemblies.
- 2.8 The carriers shall be drilled to ensure articulating axle alignment. The axles shall be held in place by retainer plates which are easily removable to allow component inspection. Dual wheel stops shall be provided to prevent wheel overload and container roll off when traveling. Stops shall be factory welded and located to clear any obstructions on the underside of the container.
- 2.9 Center portion of the drive carrier shall be equipped with steel welded lugs for connection of drive chain and swiveling clevis connectors.
- 2.10 The drive carrier shall be equipped with eight (8) double flanged, **stainless steel wheels** assembled into articulating trolley assemblies. Articulating trolley assemblies are designed to maintain equal wheel loading at all times during carrier travel. Wheels shall interface with the runway track to allow easy tracking and eliminate binding during travel.

D. ARTICULATING TROLLEY ASSEMBLIES

- 2.11 Each articulating trolley assembly shall consist of **304 stainless steel** top pivoting shaft, two (2) **304 stainless steel** heavy duty side plates, two (2) **304 stainless steel** double flanged wheels with stainless steel sealed bearings and two (2) **304 stainless steel** wheel axles. The top pivoting shaft shall secure the assembly in place on the carrier frame and allow articulating motion for equal wheel loading.
- 2.12 Wheels shall be double flanged, 5" tread diameter for operation of 1-1/2" bar track, with sealed roller bearings. Wheels to be manufactured from **304 stainless steel**. Wheels are to be mounted on the free floating axles and mounted in the heavy duty side plates. All components are easily removable for inspection and replacement if required.

E. CLOSED LOOP WINCH

- 2.13 A single speed, base mounted, positive control, dual directional electric motor driven carrier puller shall be furnished with the drive carrier. The puller shall operate at a speed to move the container at approximately 18 FPM unless otherwise indicated.
- 2.14 The puller base frame shall be a fabricated steel weldment designed for easy access to motor, gearbox and drive wheel.
- 2.15 The electric motor shall be single speed, 30 min duty rated with high starting torque characteristics. Motor shall be C-Face mounted design with minimum class B insulation. Enclosure shall be **NEMA 7**.
- 2.16 The gearbox shall be cycloidal type design providing high reduction with minimal space requirements. Cycloidal drive shall be Sumitomo, with grease lubrication. All bearing shall be rated for 5000 hours, L-10 bearing life.
- 2.17 A Zinc plated steel chain seated in a type 304 stainless steel pocket wheel mounted to the output shaft on the cycloidal gearbox shall connect to the idler sheave, also having a 304 stainless steel pocket wheel. The drive sheave and idler sheave shall be mounted in the horizontal plane for a low profile configuration. Drive chain shall run in UHMW guide channel described previously in this specification.
- 2.18 The electric motor shall be TENV 30 min. duty rating, 2 HP, single speed with high starting torque characteristics. Motor shall be C-face mounted design with minimum class B insulation. Motor shall operate on 460 volts, 3 phase, 60 hertz, control voltage to be reduced to 115 volt single phase.
- 2.19 Two magnetically operated travel limit switches shall be provided to stop carrier movement at extreme ends of the track. Steel lugs are welded to the drive and idler carriers. The steel lugs trip magnetically activated proximity switches, one mounted at each end of the track length.

F. RETURN IDLER SHEAVE

- 2.20 The return idler sheave shall be mounted horizontally inside a heavy duty **304 stainless steel** weldment designed for low profile and able to withstand truck traffic. Idler sheave is a stainless steel pocket wheel operating on roller bearings. The heavy duty steel housing includes holes for mounting the unit to concrete floors.

3.0 INSTRUMENTATION AND CONTROL SYSTEM

A. GENERAL

- 3.1 The container handling system manufacturer shall design, furnish and shop test a pedestal mounted or wall mounted control station for control of system movement. Controls shall include a 3 phase power circuit controlled by a single phase control circuit with step down transformer. The control system shall be designed to handle the expected duty cycle of the container handling system. Power supply is 460 volts 3 phase 60 hertz and the control circuit will be 120 volts 1 phase 60 hertz.
- 3.2 Control schematic shall include a variable frequency drive (VFD) used for smooth acceleration and deceleration. The inverter detects over-torque situations and opens the directional circuit, and provides dynamic braking to stop carrier movement. Other control features include a warning horn, warning light, power on indicating light and on off switch.
- 3.3 All controls are to located in a **NEMA 7 enclosure** enclosure for hazardous environments. Heaters shall be included in control enclosures. Push buttons for control of the system movement shall be mounted in the enclosure door, with indicating lights for "power on", "power off". Enclosure shall be pedestal mounted or wall mounted and located as directed by the engineer.
- 3.4 A warning horn and light shall be included with the control system. The warning horn shall sound for 15 seconds prior to the system moving, and shall be activated by the forward and reverse buttons. The warning light shall flash during horn signal, and stay flashing during system movement. Light and horn shall be mounted and located as directed by the engineer.

4.0 PAINTING

A. GENERAL

- 4.1 Stainless steel surfaces shall not be painted. The motor shall be provided with the manufacturers standard finish. Surfaces shall be hand cleaned with a wire brush and wiped with solvent prior to painting equipment.
- 4.2 Equipment shall be touch painted in the field after installation. All marks and abrasions shall be primed if required, and finish coated.

5.0 INSTALLATION

A. GENERAL

- 5.1 Installation shall be in accordance with the manufacturer's recommendations, and performed with qualified persons. Tracks shall be anchored to the building floor with stainless steel threaded rod and Epcon Epoxy System, or expansion anchors depending on surface conditions.
- 5.2 The Epcon mounting system incorporates a leveling nut under track to set elevation of track along the length. After installation, grout shall be installed under track along the entire length. Drive winch and idler sheave shall be installed the same way if the Epcon system is used.

- 5.3 The concrete floor shall have a constant slope in one direction, not exceeding 1/4" per 10'-0" of run for run-off purposes. Trench drains running perpendicular to the tracks at intervals dictated by the engineer is the preferred method for drainage in a new facility.
- 5.4 Track, guide channel, drive and idler shall be installed at the same elevation (+-) 1/4". Care should be taken to ensure alignment of guide track to drive chain during installation.

## 6.0 TESTING AND START-UP

### A. GENERAL

- 6.1 The container handling system shall be tested for proper operation prior to being put into service. All controls, lights, horns, limit switches and stops shall be tested in a no-load situation.
- 6.2 A container to be provided by others can be used to perform a partial load test. The container, delivery of the container and removal of the container is to be provided by the owner. An operational and partial load test will be performed with an empty container. The owner is responsible for obtaining a loaded container to perform a full load test.
- 6.3 Tests shall include operating the equipment the full length of the tracks, checking travel limit switches and carrier operation.

END OF SECTION

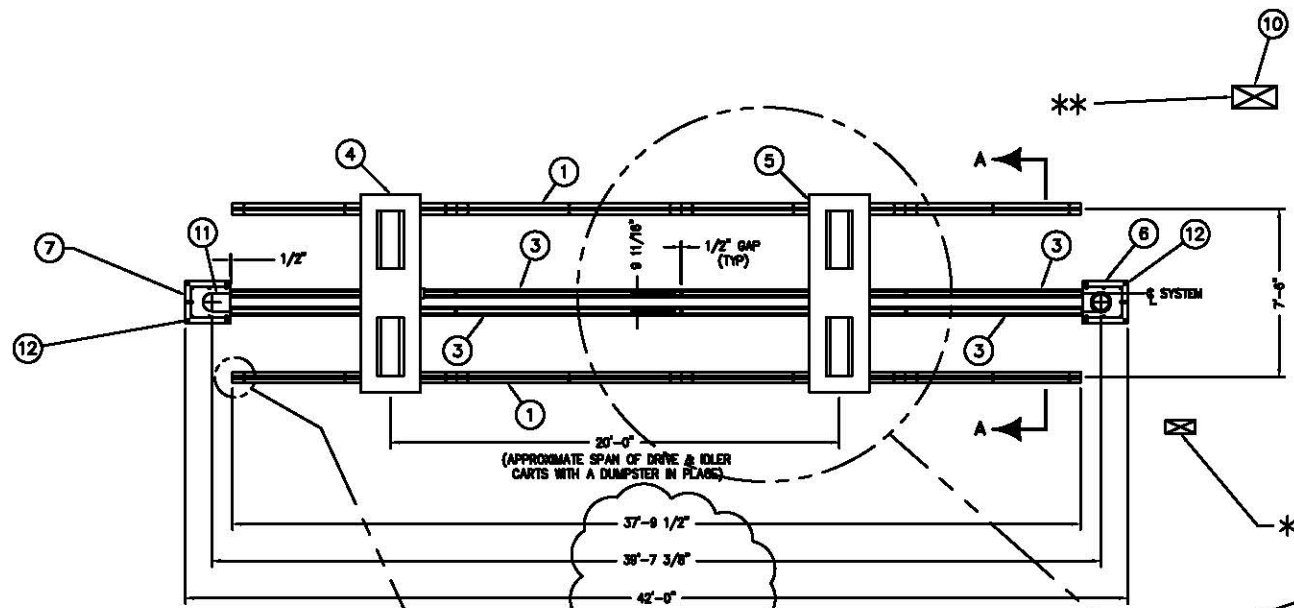

- PLAN VIEW -

\* - WARNING HORN & LIGHT TO BE MOUNTED IN THE AREA AS DETERMINED DURING DESIGN

\*\* - WALL MOUNTED CONTROL STATION PLEASE ADVISE AS TO LOCATION

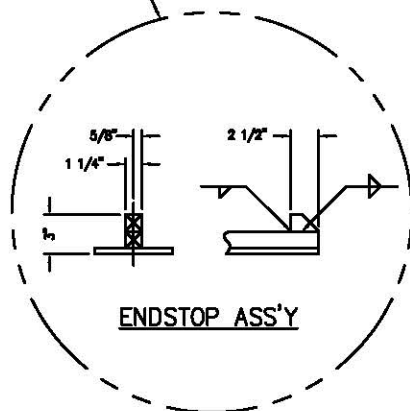

ENDSTOP ASS'Y

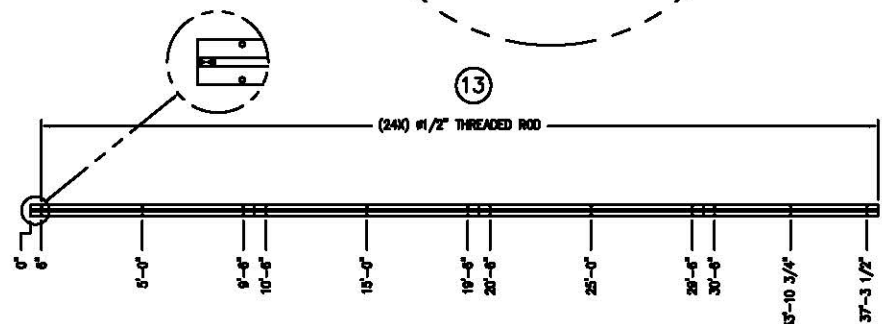

TYPICAL ANCHOR LAYOUT FOR RAIL ASSEMBLY

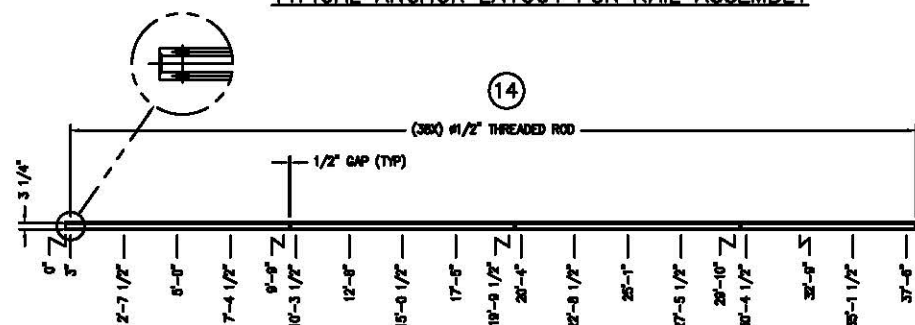

TYPICAL ANCHOR LAYOUT FOR CHAIN GUIDE

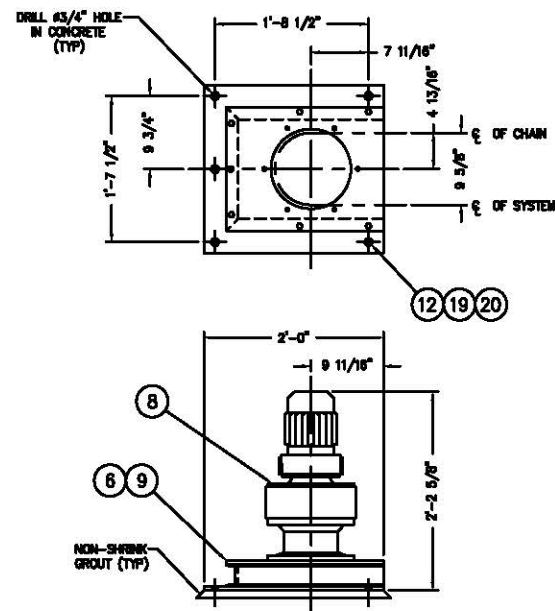

DRIVE BASE ASSEMBLY

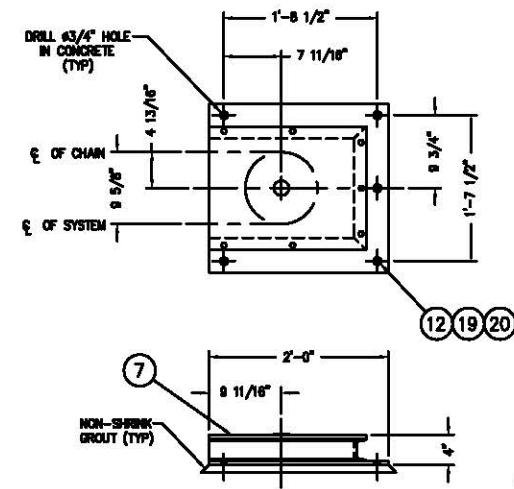

IDLER BASE ASSEMBLY

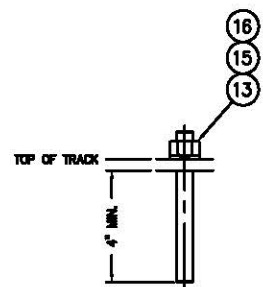
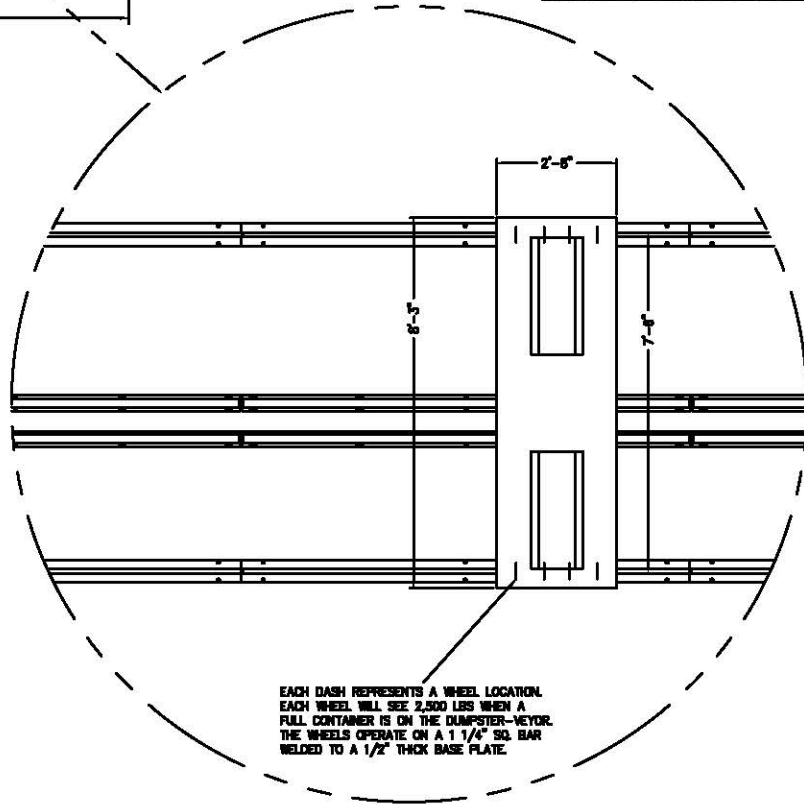

TYPICAL ANCHOR (STEEL TRACK)

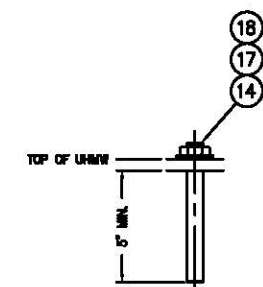

TYPICAL ANCHOR (UHMW TRACK)

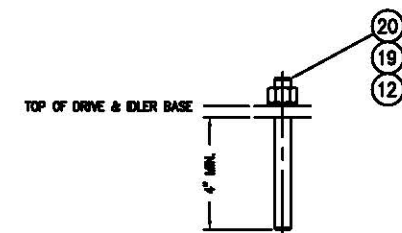

TYPICAL ANCHOR (DRIVE & IDLER BASE)

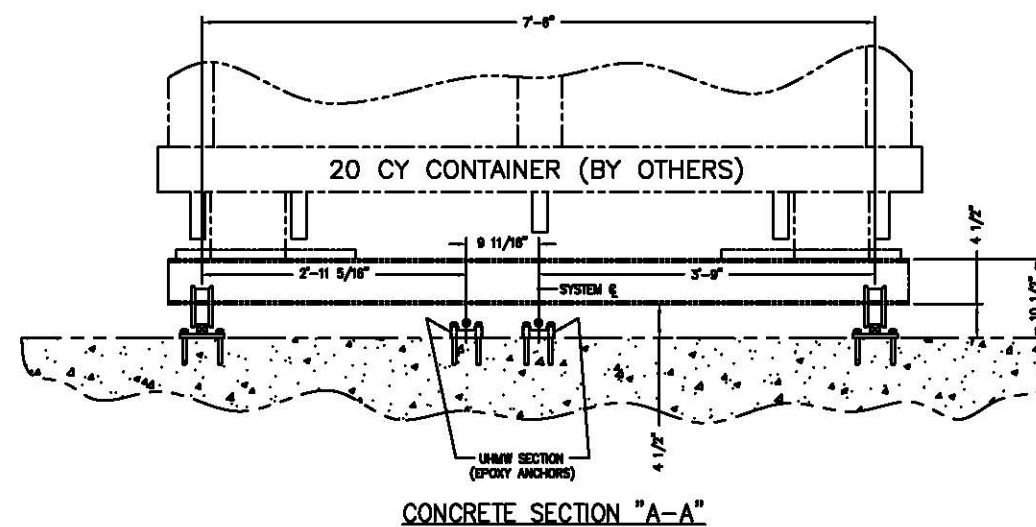

CONCRETE SECTION "A-A"

GENERAL NOTES:

- DRIVE & IDLER BASES AVAILABLE IN MILD OR STAINLESS STEEL. WHEELS, AXLES, TROLLEY SIDE PLATES, TRACK, POCKET WHEELS, DRIVE CART, IDLER CARTS ARE AVAILABLE IN MILD OR STAINLESS STEEL. ZINC PLATED: DRIVE CHAIN ASSEMBLY
- PREP/PAINT SPECIFICATION: SSPC-SP10 SHERWIN-WILLIAMS (2) Coat Macropoxy
- FIELD WIRING TO BE BY OTHERS.

ITEM	QTY	DESCRIPTION
20	10	#3/4" FLAT WASHER (DRIVE & IDLER BASE)
19	10	3/4-10 HEX NUT (DRIVE & IDLER BASE)
18	80	#1/2" FLAT WASHER (UHMW GUIDE)
17	80	1/2-13 HEX HALF NUT (UHMW GUIDE)
16	48	#1/2" LOCK WASHER (STEEL TRACK)
15	48	1/2-13 HEX NUT (STEEL TRACK)
14	80	1/2-13 x 6" LG. ST. STL. ANCHOR
13	48	1/2-13 x 6" LG. ST. STL. ANCHOR
12	10	3/4-10 x 6" LG. ST. STL. ANCHOR
11	1	DRIVE CHAIN ASS'Y.
10	1	Nema 4X CONTROL ENCLOSURE (WALL MOUNTED)
9	2	TRAVEL PROXIMITY SWITCH
8	1	PYRAMIDAL TYPE FLANGE MOUNTED DOUBLE REDUCTION, BI DIRECTIONAL CYCLOID DRIVE OPERATING @ 18 FPM SINGLE SPEED (1 1/2 H.P. 1750 RPM) FRAME BRAKE FOR INDEPENDANT OPERATION, C-FACE ADAPTER, INPUT COUPLING, INTEGRAL DUAL ROTATION TORQUE LIMITER, BRAKE RESISTOR AND POCKET WHEEL ASSEMBLY
7	1	IDLER SHEAVE BASE ASS'Y.
6	1	DRIVE MOUNTING BASE ASS'Y.
5	1	IDLER CART ASS'Y.
4	1	DRIVE CART ASS'Y.
3	2	UHMW CHAIN GUIDE
2	-	-
1	2	RUNWAY TRACK - (37'-9 1/2" EACH)

APPROVED BY: \_\_\_\_\_  
 DATE: \_\_\_\_\_  
 VOLTAGE: 460-3-60 CONTROL: 115v

NOTE: UNLESS OTHERWISE STATED, ALL FIELD WORK, BUILDING SYSTEMS, MATERIALS AND FINISHES TO BE BY OTHERS. D. R. CORDELL & ASSOC., INC. CLAIMS PROPRIETARY RIGHTS TO ALL IDEAS AND TECHNICAL INFORMATION FURNISHED HEREIN, AND SAID INFORMATION MAY NOT BE REPRODUCED, REPRODUCED OR USED IN ANY MANNER WITHOUT THE EXPRESS WRITTEN CONSENT OF D. R. CORDELL & ASSOC., INC.

**D.R. CORDELL & ASSOC., INC.**  
 CHALFONT, PA 18914 215-822-9346

CLEARANCE DRAWING  
 20 CUBIC YARD DUMPSTER-VEYOR

for:		REV.
SCALE 1/4"=1'-0"	JOB NO. DV-2 SINGLE SYSTEM	D
DATE	DESIGNED BY D.R.C.	
BY RJR	CHECKED BY	
SHT 1 OF 1	DESCRIPTION DV-S Single	0

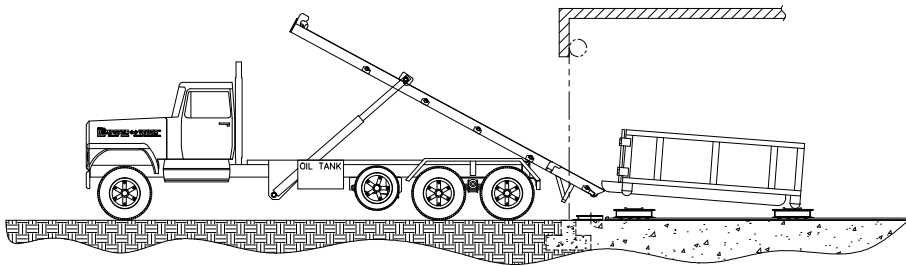
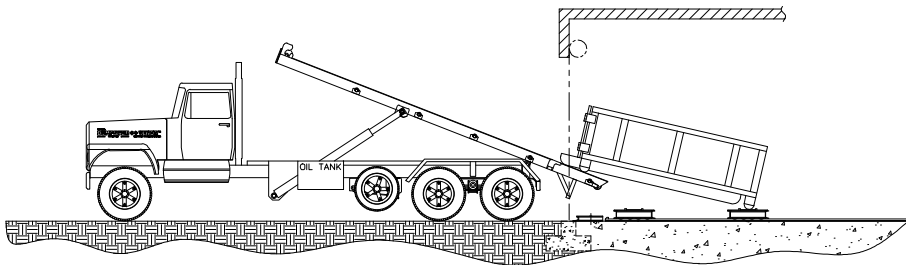
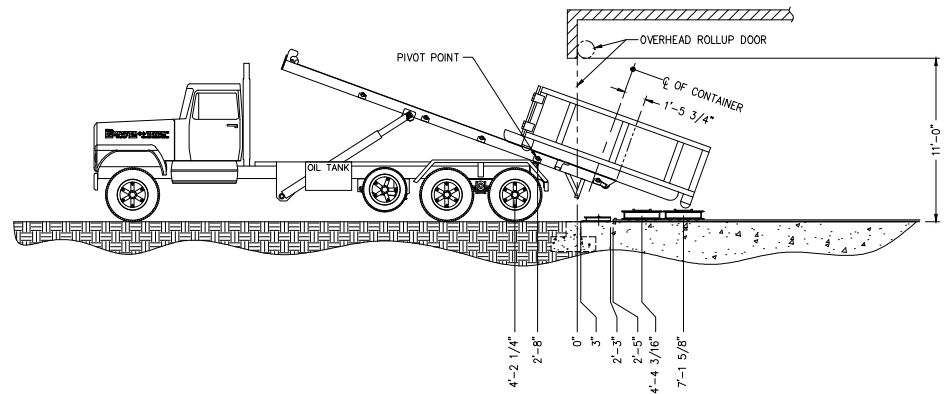
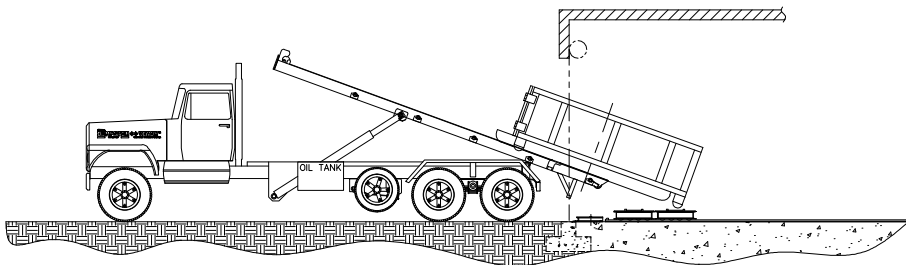
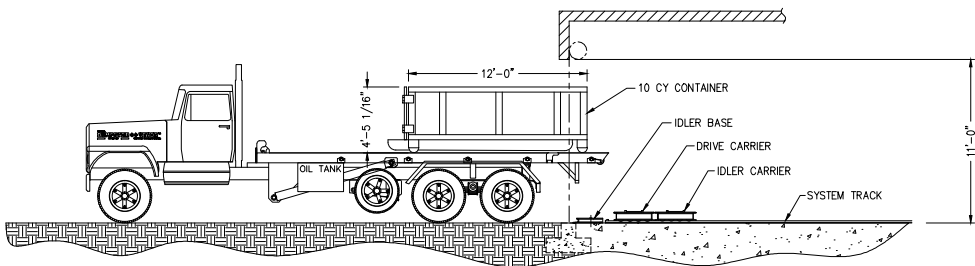

WWW.CORDELLMFG.COM 215-822-9345	
DUMPSTER UNLOADING LAYOUT 10 CUBIC YARD CONTAINER	
SCALE 1/4"=1'-0"	ORD FILE 10 CY UNLOADING
DATE 10.09.14	JOB NO. D.R.C. #
BY RJR	DRAWING NO.
SHT 1 OF 1	10CY UNLOAD
	REV. 0

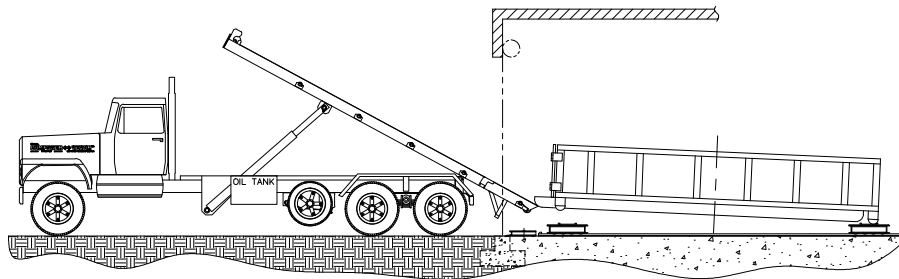
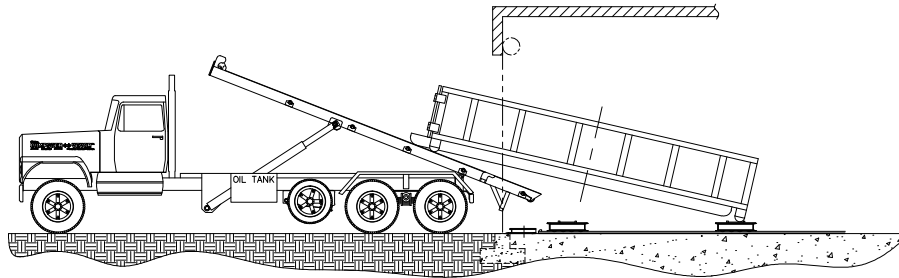
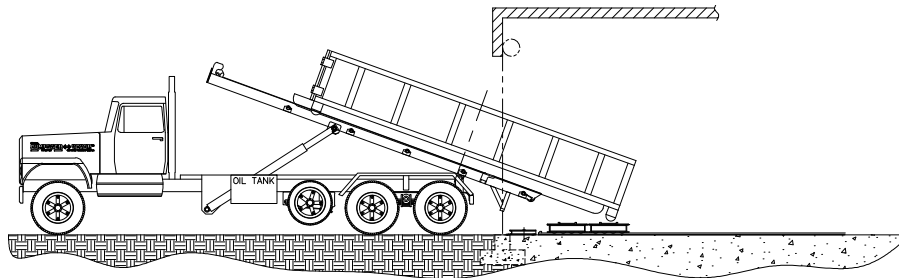
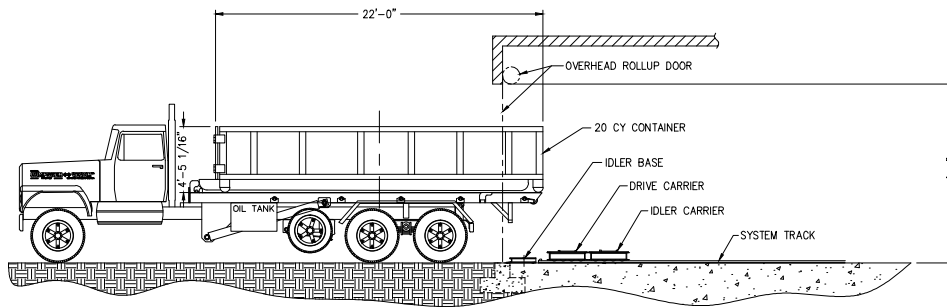

		<b>D</b>		
WWW.COWDELLMFG.COM 215-822-9345				
DUMPSHED UNLOADING LAYOUT 20 CUBIC YARD CONTAINER				
SCALE	1/4"=1'-0"	CAD FILE	20 CY UNLOADING	
DATE	10.09.14	JOB NO.	D.R.C. #	
BY	RJR	DRAWING NO.	20CY UNLOAD	
SHT	1 OF 1		REV.	0

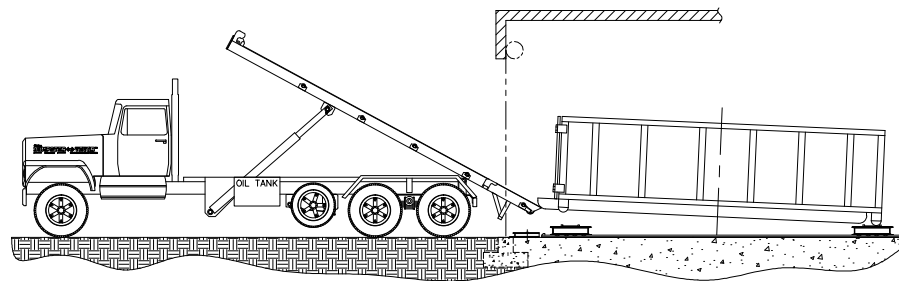
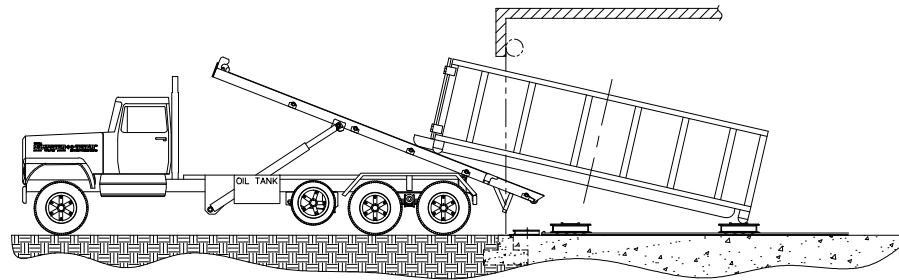
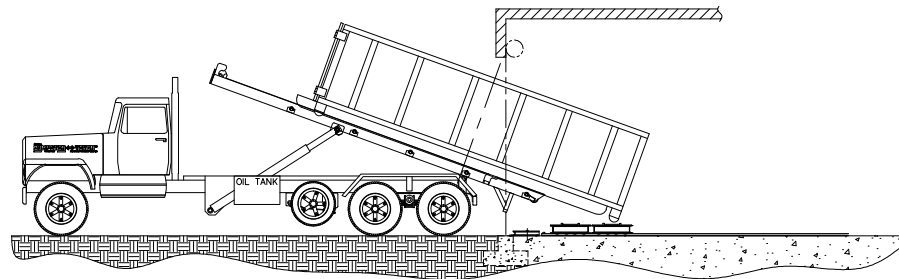
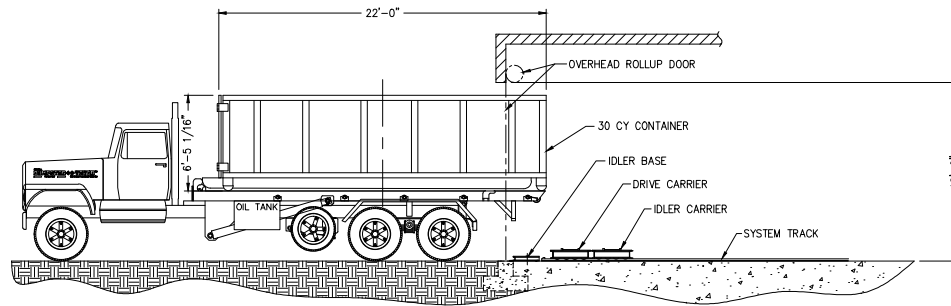

		<b>D</b>	
WWW.CORDELLMFG.COM 215-822-9345			
DUMPSHED UNLOADING LAYOUT 30 CUBIC YARD CONTAINER			
SCALE	1/4"=1'-0"	ORD FILE	30 CY UNLOADING
DATE	10.09.14	JOB NO.	D.R.C. #
BY	RJR	DRAWING NO.	30CY UNLOAD
SHT	1 OF 1		REV. 0